

野火_RK3566_LUBANCAT_ZERO_WIFI_原理图

目录

Page 1	Content
Page 2	Historic Version
Page 3	POWER DIAGRAM
Page 4	TYPE_C_POWER/OTG/USB
Page 5	PMIC_DCDC/LDO
Page 6	PMIC_Management/CODE
Page 7	Power_other
Page 8	RK3566_Power/GND
Page 9	RK3566_DDR PHY
Page 10	LPDDR4/4x
Page 11	RK3566_OSC/PLL/PMUIO
Page 12	RK3566_EMMC/SD Controller
Page 13	RK3566_USB/PCIe/SATA PHY
Page 14	MIPI_DSI/EDP/HDMI_Controller
Page 15	MIPI_CSI/GMAC_Controller
Page 16	RK3566_Audio Interface
Page 17	RK3566_SARADC/GPIO
Page 18	RK3566_VO Interface
Page 19	HDMI_PORT
Page 20	WLAN_BT
Page 21	MIPI_DSI/MIPI_CSI_PORT
Page 22	DEBUG/PIN_OUT
Page 23	
Page 24	
Page 25	
Page 26	

东莞野火电子有限公司 https://yehuosm.tmall.com		
Title 野火_RK3566_LUBANCAT_ZERO_WIFI_原理图		
Size A3	Document Number Content	Rev V0.2
Date: Thursday, December 08, 2022 Sheet 1 of 22		

历史版本

版本号	日期	设计	描述
V0.1	2022-04-18	ghs	初始版本
V0.2	2022-07-19	ghs	修正mini HDMI引脚定义, mipi csi添加两对数据线

东莞野火电子有限公司 https://yehuosm.tmall.com		
Title 野火_RK3566_LUBANCAT_ZERO_WIFI_原理图		
Size A3	Document Number Historic Version	Rev V0.2
Date: Thursday, December 08, 2022 Sheet 2 of 22		

POWER DIAGRAM

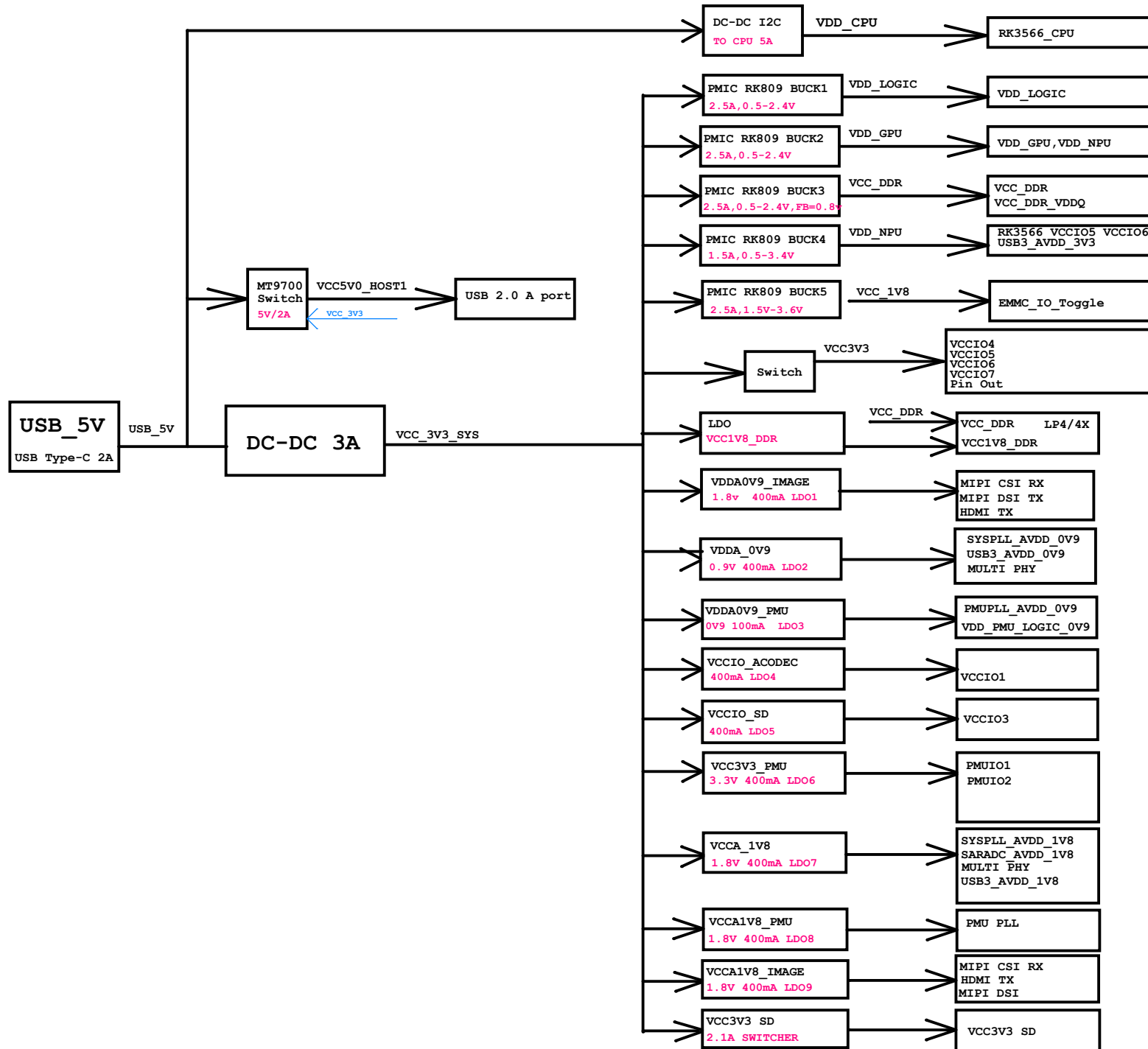

东莞野火电子有限公司 https://yehuosm.tmall.com		
Title	野火_RK3566_LUBANCAT_ZERO_WIFI_原理图	
Size	Document Number	Rev
A3	POWER DIAGRAM	0.2
Date:	Thursday, December 08, 2022	Sheet 3 of 22

POWER IN

OTG Download

5V 3A

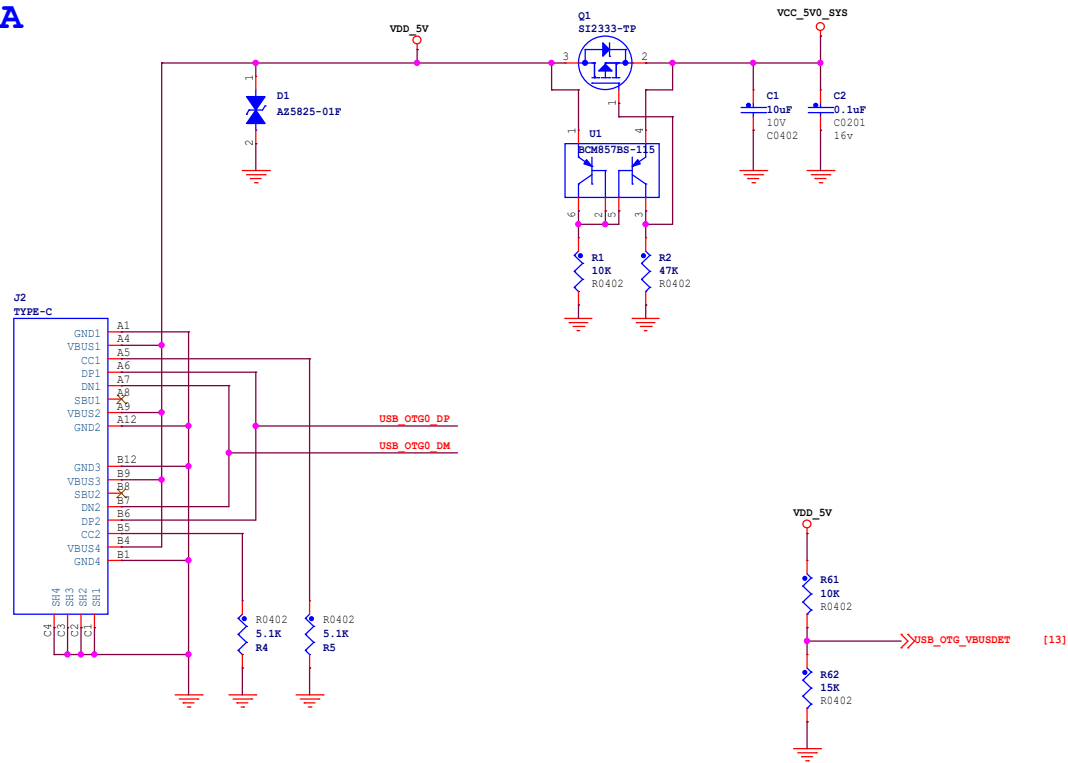

USB 2.0 HOST x1

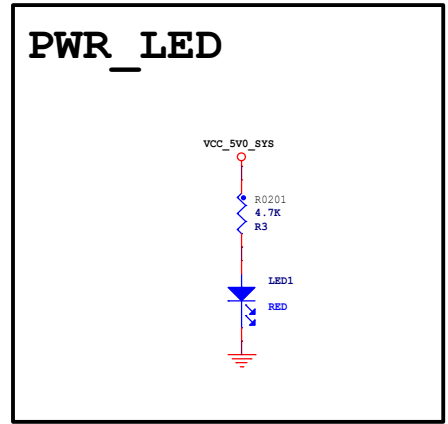
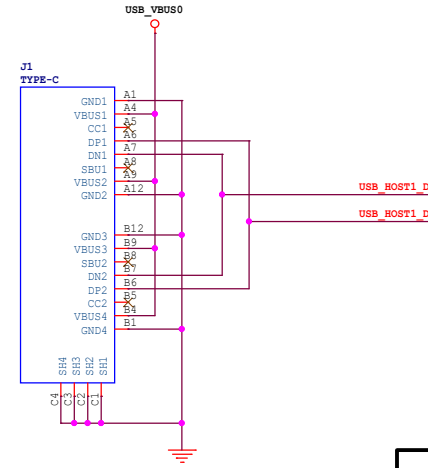

机械定位孔

4*M2.5

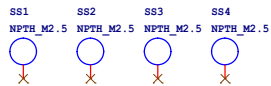

USB ESD

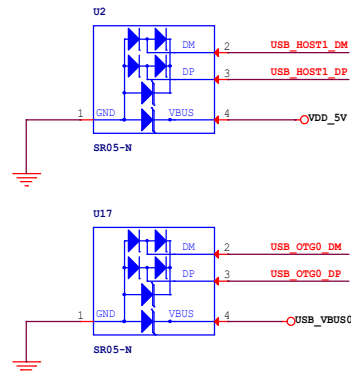

USB POWER

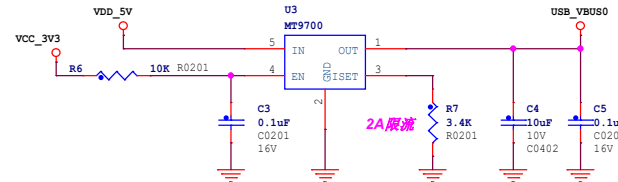

东莞野火电子有限公司
https://yehuosm.tmall.com

Title 野火_RK3566_LUBANCAT_ZERO_WIFI_原理图		
Size A3	Document Number TYPE_C_POWER/OTG	Rev V0.2
Date: Thursday, December 08, 2022	Sheet 4	of 22

PMIC RK809 DCDC

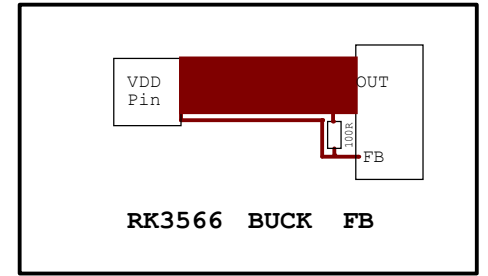
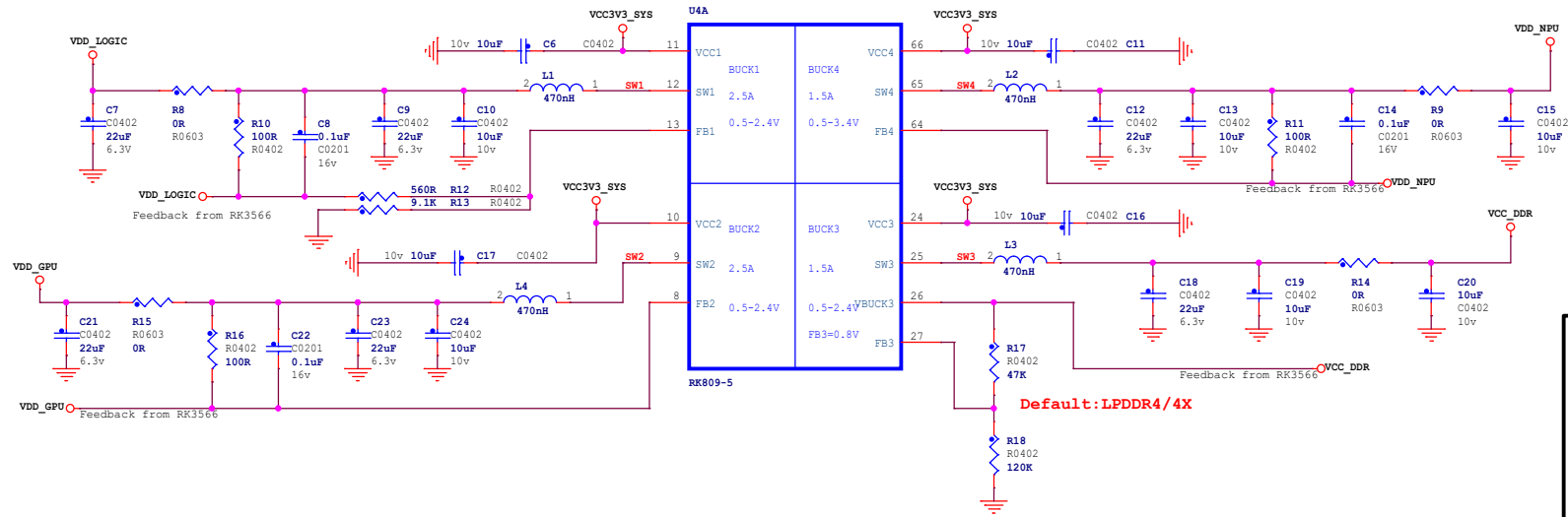

PMIC RK809 LDO

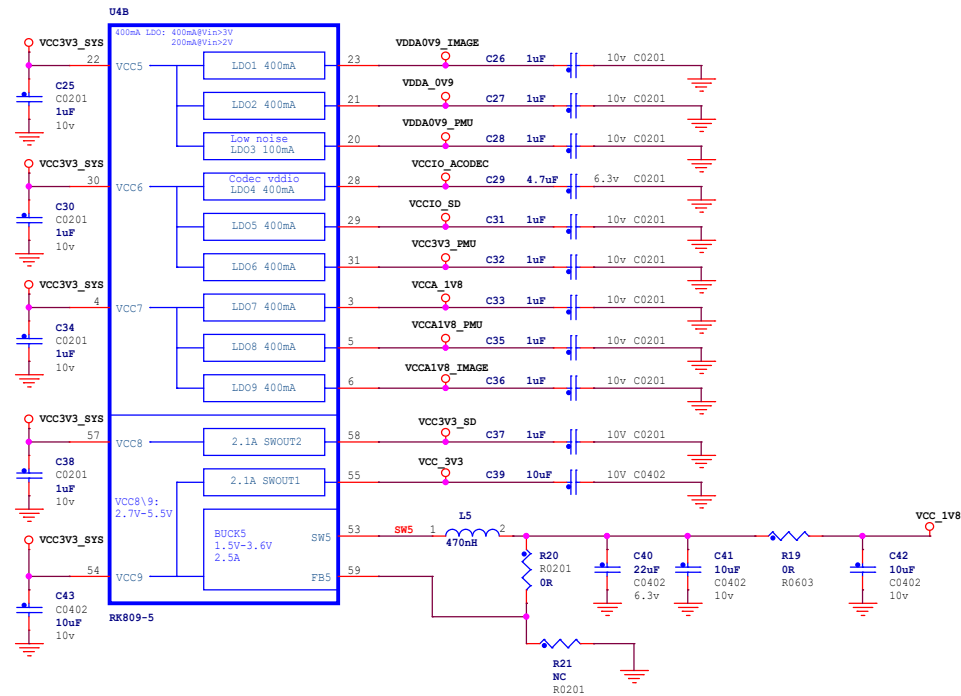

东莞野火电子有限公司 https://yehuosm.tmall.com		
Title 野火_RK3566_LUBANCAT_ZERO_WIFI_原理图		
Size A3	Document Number PMIC_DCDC/LDO	Rev V0.2
Date: Thursday, December 08, 2022	Sheet 5	of 22

PMIC RK809 Managerment

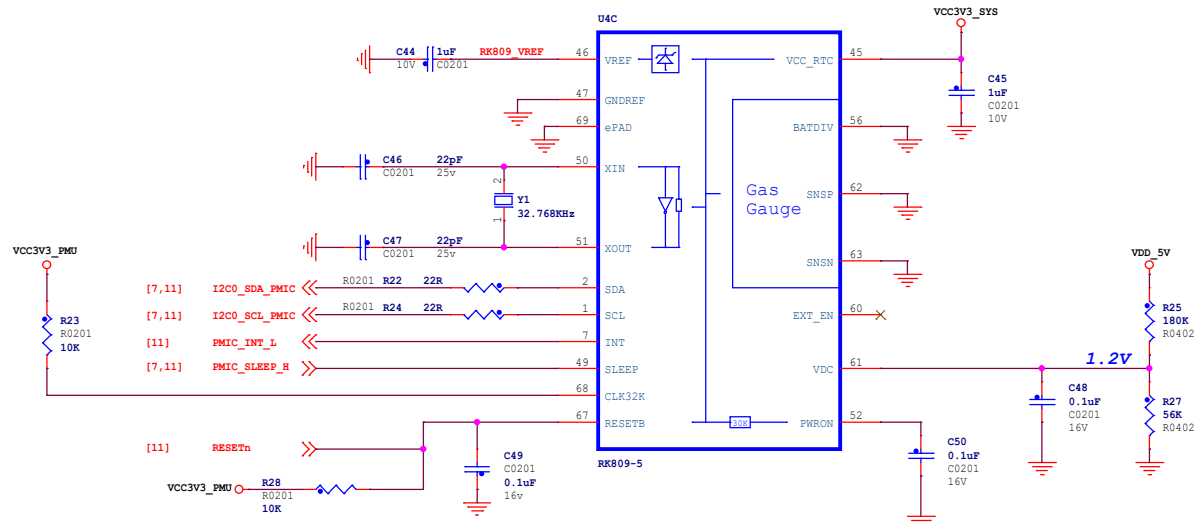

PMIC RK809 CODEC

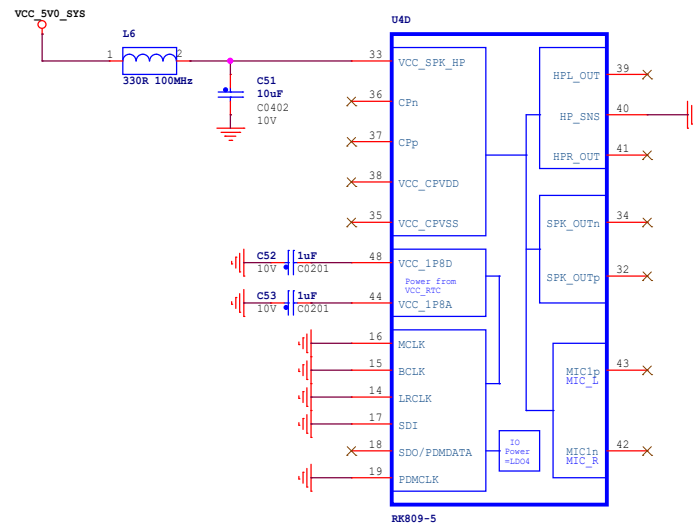

东莞野火电子有限公司
<https://yehuosm.tmall.com>

Title 野火_RK3566_LUBANCA7_ZERO_WIFI_原理图		
Size A3	Document Number PMIC_Management/CODE	Rev V0.2
Date: Thursday, December 08, 2022 Sheet 6 of 22		

RK3566_ABCDE (Power&GND)

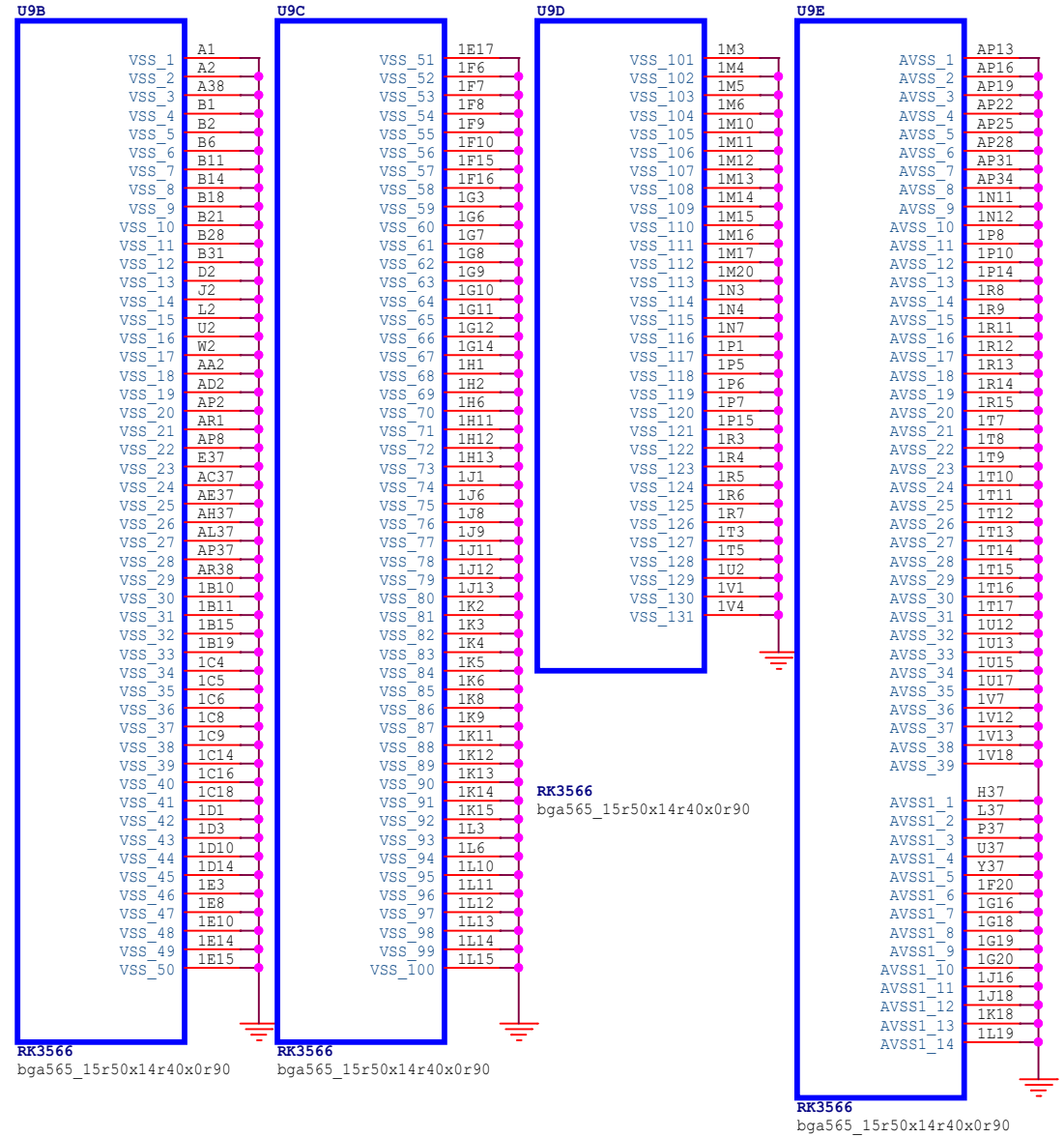
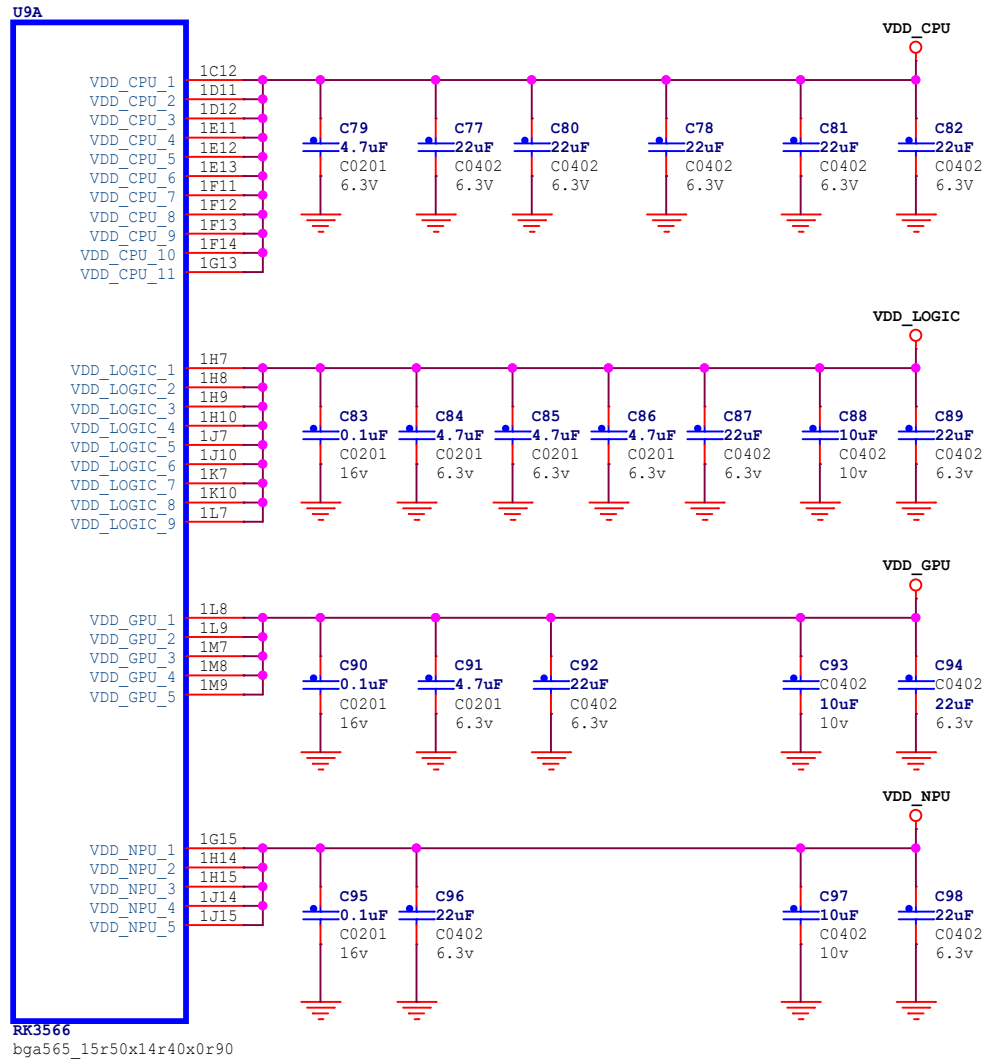

东莞野火电子技术有限公司 https://yehuosm.tmall.com		
Title 野火_RK3566_LUBANCAT_ZERO_WIFI_原理图		
Size A4	Document Number RK3566_Power/GND	Rev V0.2
Date: Thursday, December 08, 2022 Sheet 8 of 22		

RK3566_F (DDR PHY)

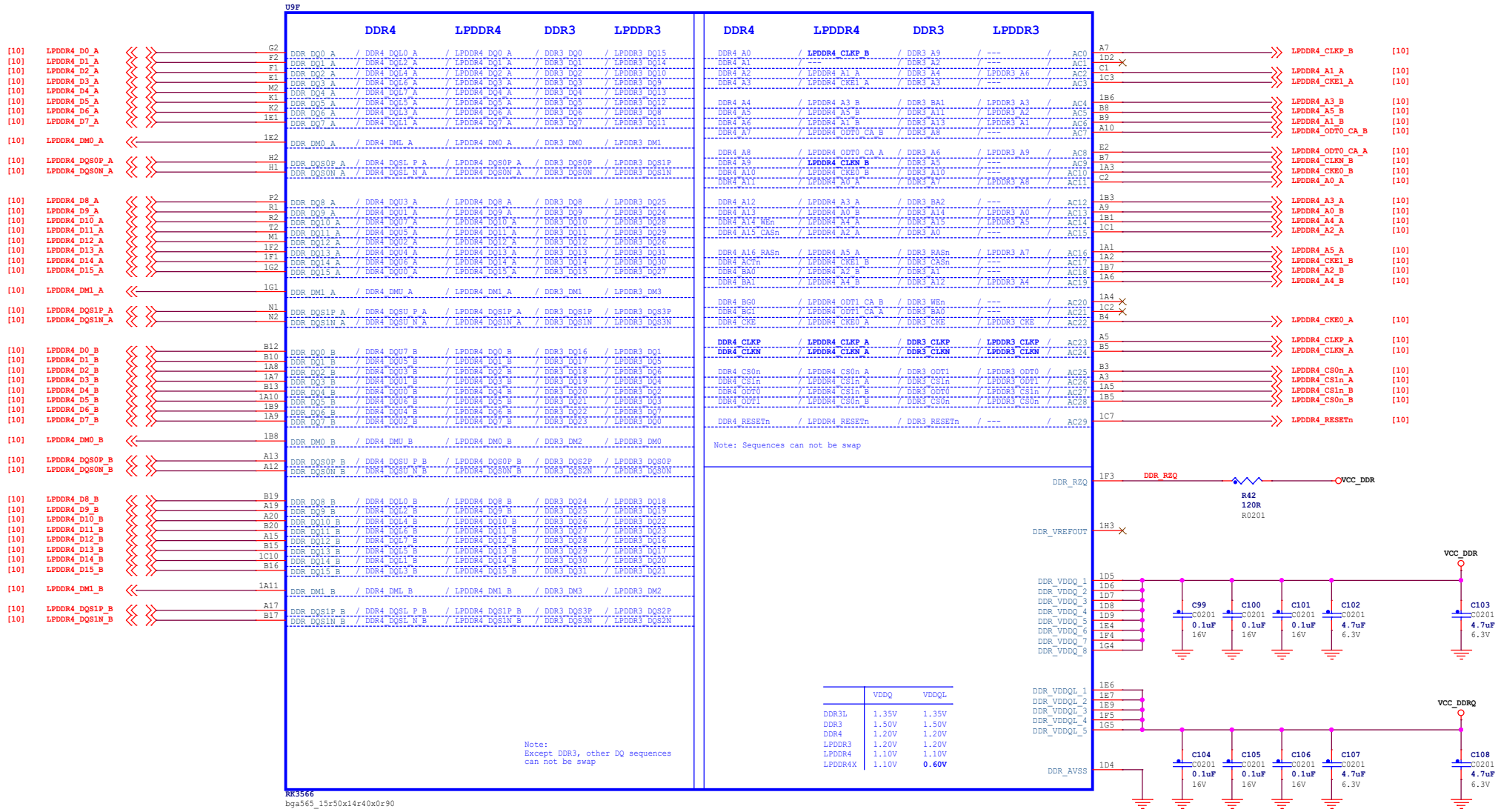

LPDDR4/4x

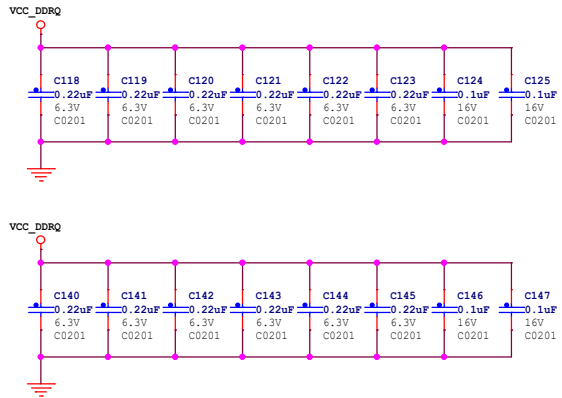
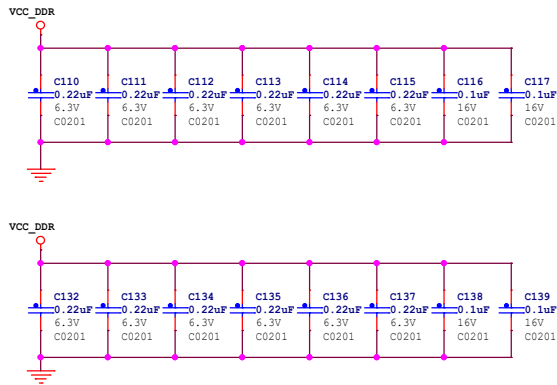
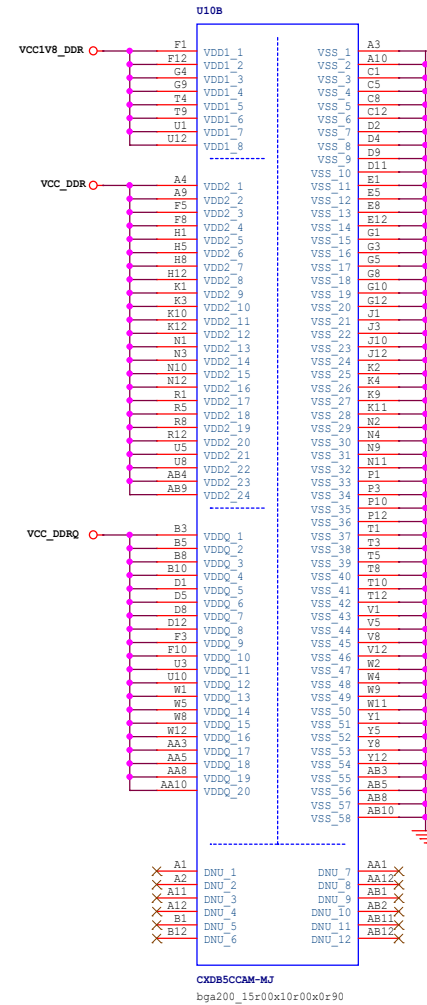
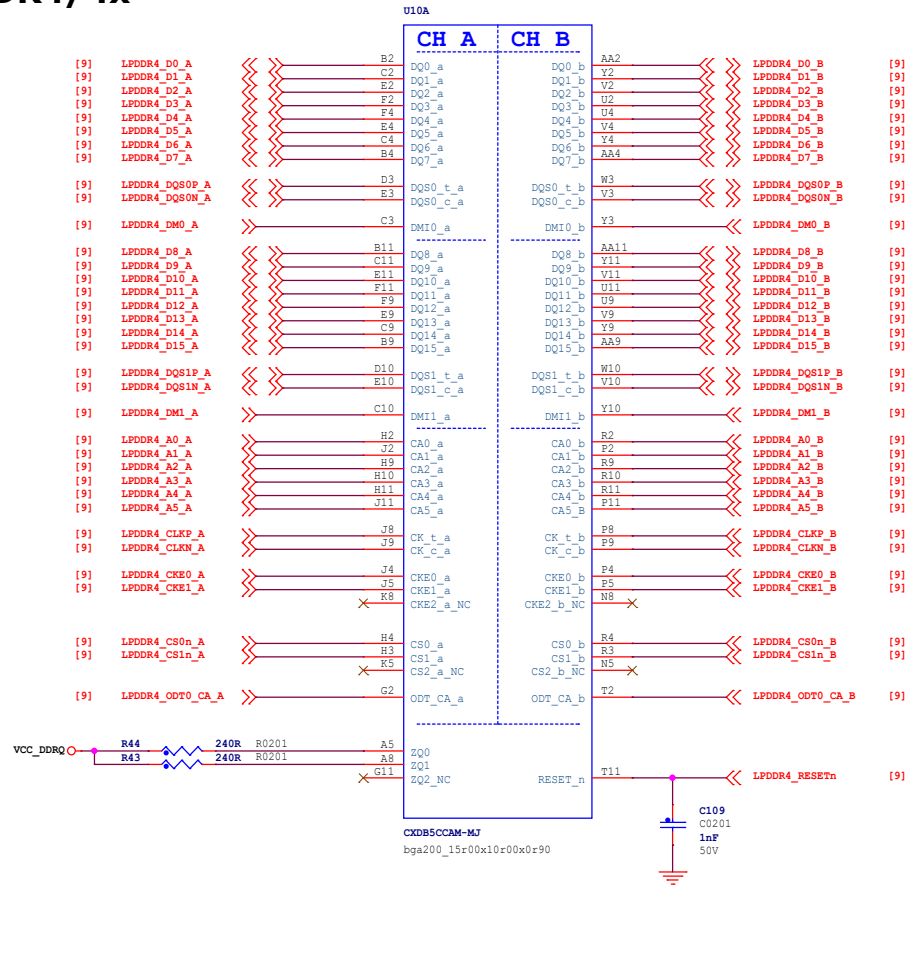

东莞野火电子有限公司 https://yehuoem.taobao.com		
Title: 野火_RK3566_LUBANCA7_ZERO_WIFI_原理图		
Size: A3	Document Number: LPDDR4/4x	Rev: V0.2
Date: Thursday, December 08, 2022 Sheet 10 of 22		

RK3566_I (VCCIO2 Domain) EMMC_IO

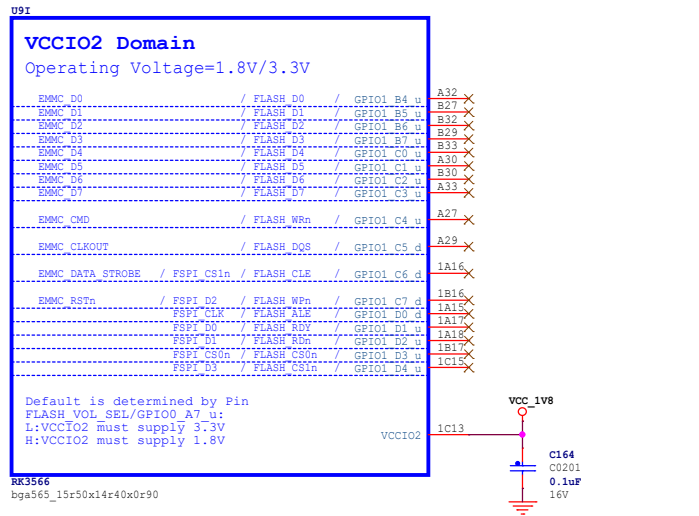

RK3566_J (VCCIO3 Domain) SDMMC_IO

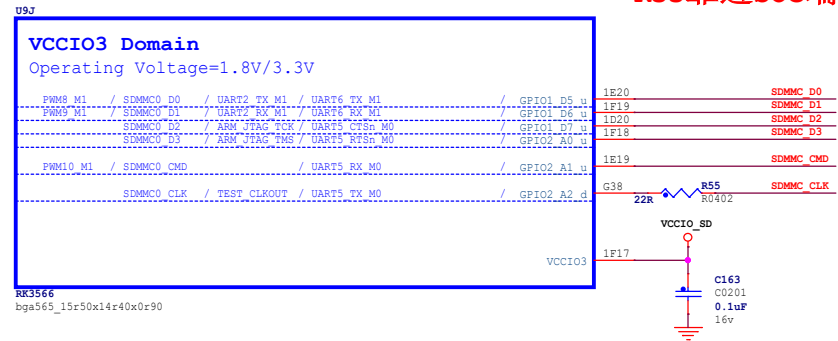

TF_CARD

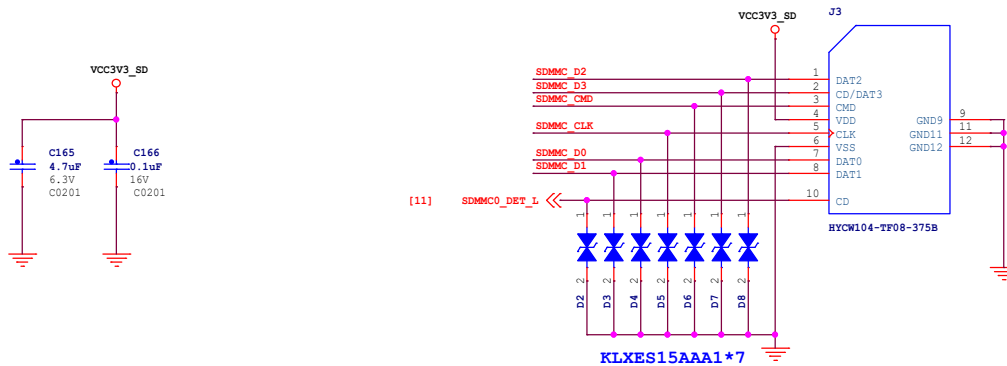

东莞野火电子有限公司 https://yehuosm.tmall.com		
Title 野火_RK3566_LUBANCAT_ZERO_WIFI_原理图		
Size A3	Document Number RK3566_EMMC/SD Controller	Rev V0.2
Date: Thursday, December 08, 2022	Sheet 12	of 22

RK3566_U (USB3.0/SATA/PCIe2.0 x1)

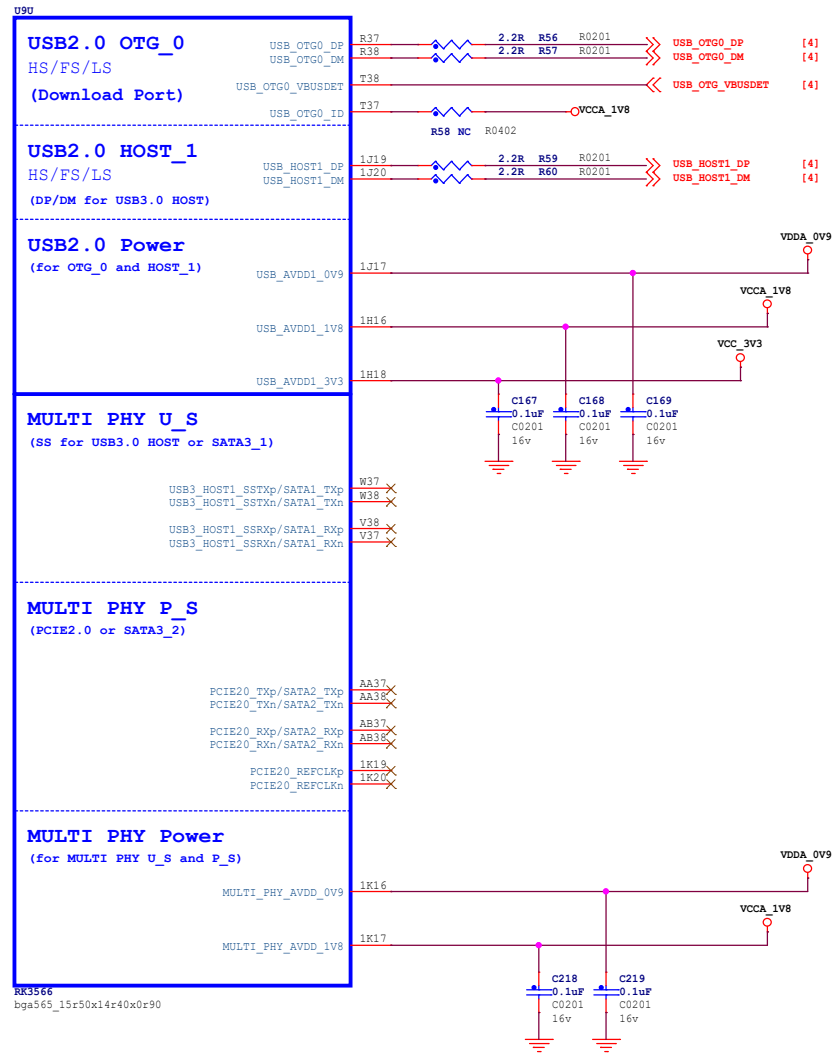

RK3566_V (USB2.0 HOST)

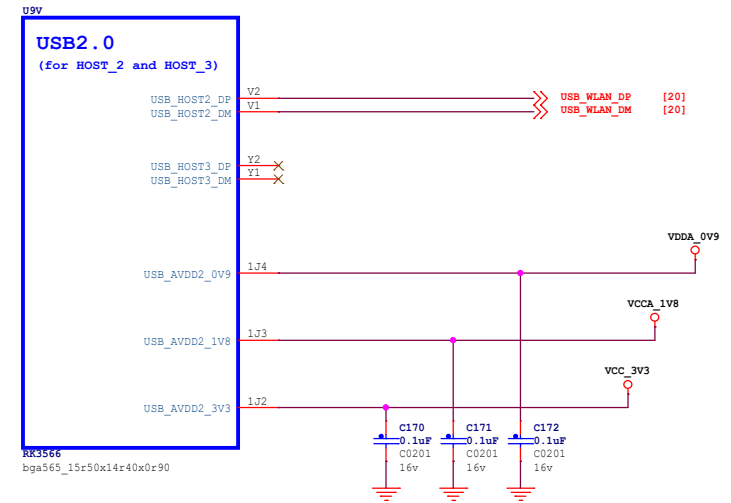

东莞野火电子有限公司 https://yehuosm.tmall.com		
Title 野火_RK3566_LUBANCAT_ZERO_WIFI_原理图		
Size A3	Document Number RK3566_USB/PCIe/SATA_PHY	Rev V0.2
Date: Thursday, December 08, 2022	Sheet 13	of 22

RK3566_R (MIPI_DSI_TX0/LVDS_TX0)

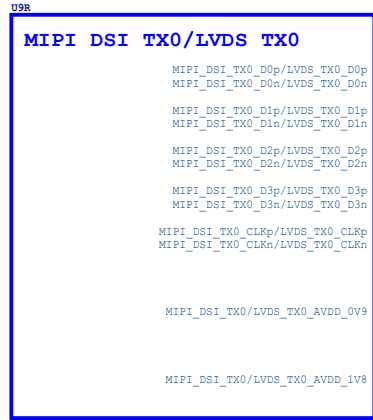

AP30	MIPI_DSI_TX0_D0p	(21)
AR30	MIPI_DSI_TX0_D0n	(21)
AR29	MIPI_DSI_TX0_D1p	(21)
AF29	MIPI_DSI_TX0_D1n	(21)
AR27	MIPI_DSI_TX0_D2p	(21)
AR27	MIPI_DSI_TX0_D2n	(21)
AR26	MIPI_DSI_TX0_D3p	(21)
AF26	MIPI_DSI_TX0_D3n	(21)
1V16	MIPI_DSI_TX0_CLKp	(21)
1V15	MIPI_DSI_TX0_CLKn	(21)



RK3566
bga565_15r50x14r40x0r90

RK3566_S (MIPI_DSI_TX1)

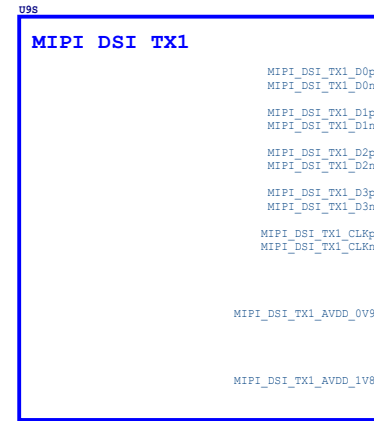

AP24	MIPI_DSI_TX1_D0p	(21)
AR24	MIPI_DSI_TX1_D0n	(21)
AR21	MIPI_DSI_TX1_D1p	(21)
AF21	MIPI_DSI_TX1_D1n	(21)
AP21	MIPI_DSI_TX1_D2p	(21)
AR21	MIPI_DSI_TX1_D2n	(21)
AR20	MIPI_DSI_TX1_D3p	(21)
AF20	MIPI_DSI_TX1_D3n	(21)
1V11	MIPI_DSI_TX1_CLKp	(21)
1U11	MIPI_DSI_TX1_CLKn	(21)



RK3566
bga565_15r50x14r40x0r90

RK3566_T (eDP/DP TX)

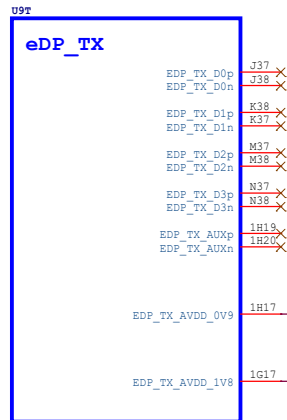

RK3566
bga565_15r50x14r40x0r90

RK3566_Q (HDMI2.0 TX)

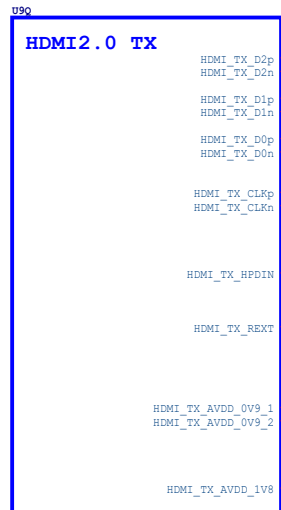

AP36	HDMI_TX_D2p	(19)
AR36	HDMI_TX_D2n	(19)
AR35	HDMI_TX_D1p	(19)
AF35	HDMI_TX_D1n	(19)
AP33	HDMI_TX_D0p	(19)
AR33	HDMI_TX_D0n	(19)
AR32	HDMI_TX_CLKp	(19)
AP32	HDMI_TX_CLKn	(19)

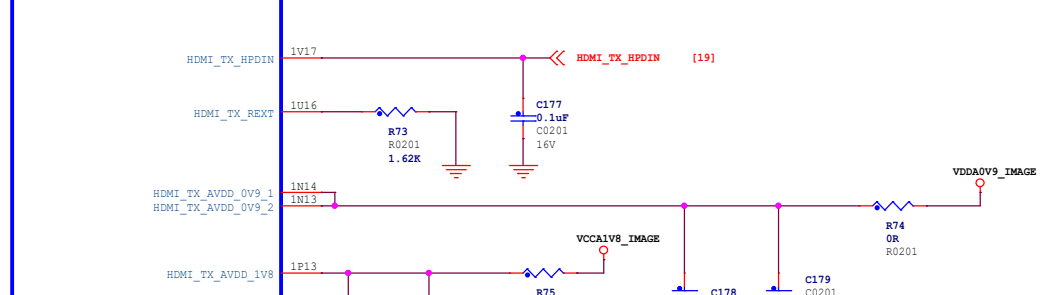

RK3566
bga565_15r50x14r40x0r90

东莞野火电子技术有限公司 https://yehuosm.tmall.com		
Title 野火_RK3566_LUBANCAT_ZERO_WIFI_原理图		
Size A3	Document Number MIPI_DSI/EDP/HDMI_Controller	Rev V0.2
Date: Thursday, December 08, 2022 Sheet 14 of 22		

RK3566_M(VCCIO6 Domain)

GMAC_Controller

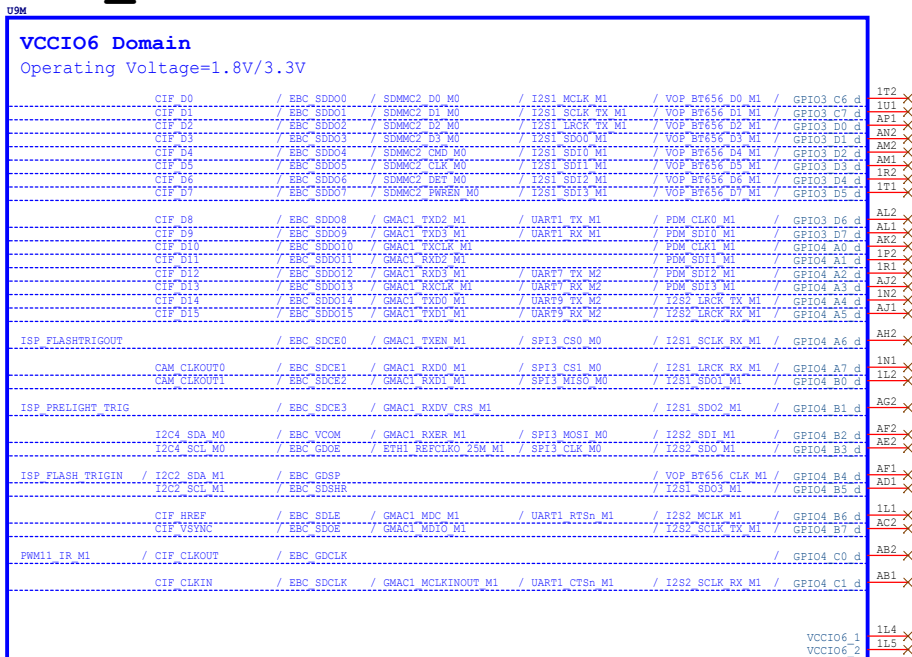

RK3566
bga565_15r50x14r40x0r90

RK3566_P(MIPI_CSI_RX)

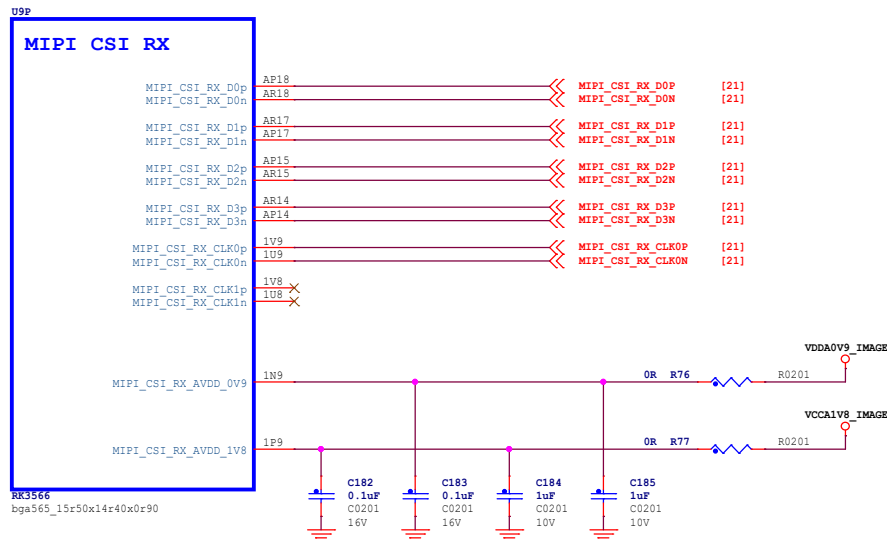

RK3566
bga565_15r50x14r40x0r90

东莞野火电子有限公司 https://yehuosm.tmall.com		
Title	野火_RK3566_LUBANCA7_ZERO_MIPI_原理图	
Size	Document Number	Rev
A3	MIPI_CSI/GMAC_Controller	V0.2
Date:	Thursday, December 08, 2022	Sheet 15 of 22

RK3566_H (VCCIO1 Domain)

U9H

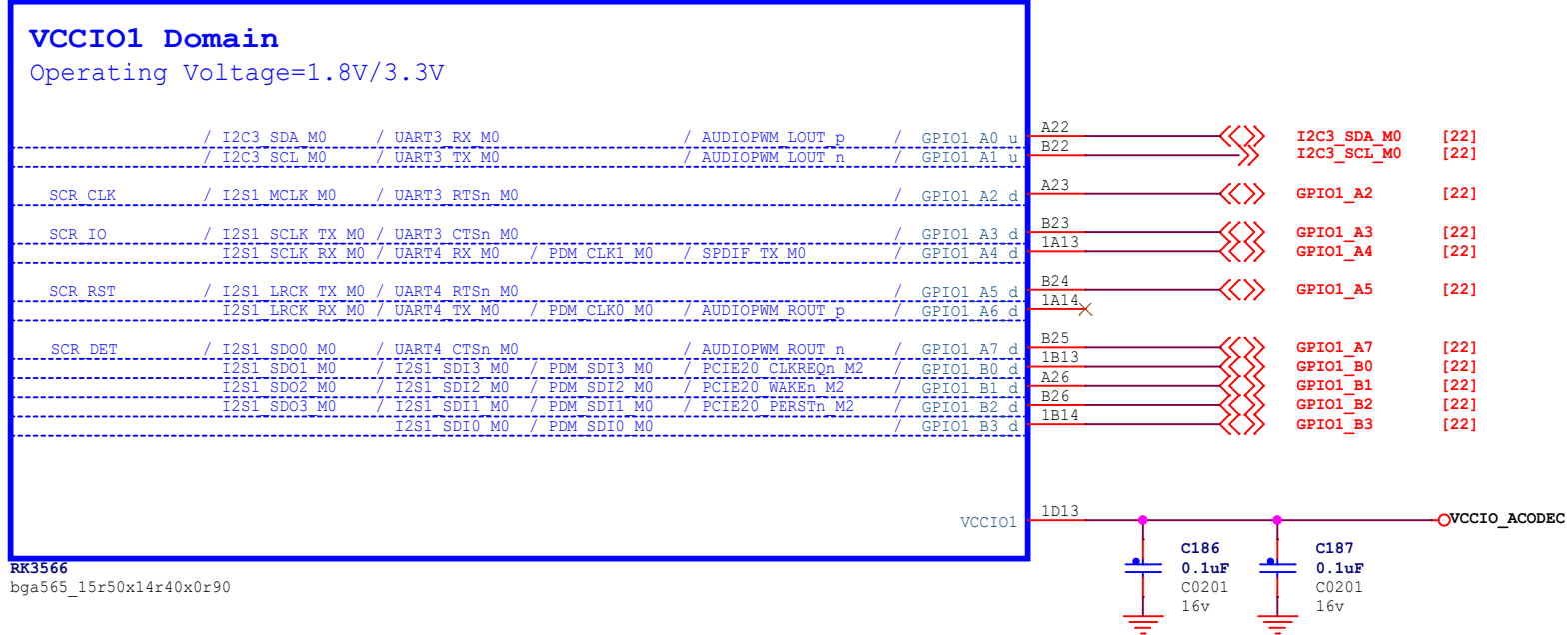

RK3566
bga565_15r50x14r40x0r90

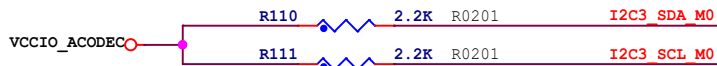

东莞野火信息技术有限公司 https://yehuosm.tmall.com		
Title 野火_RK3566_LUBANCAT_ZERO_WIFI_原理图		
Size A4	Document Number RK3566_Audio Interface	Rev V0.2
Date: Thursday, December 08, 2022 Sheet 16 of 22		

RK3566_K (VCCIO4 Domain)

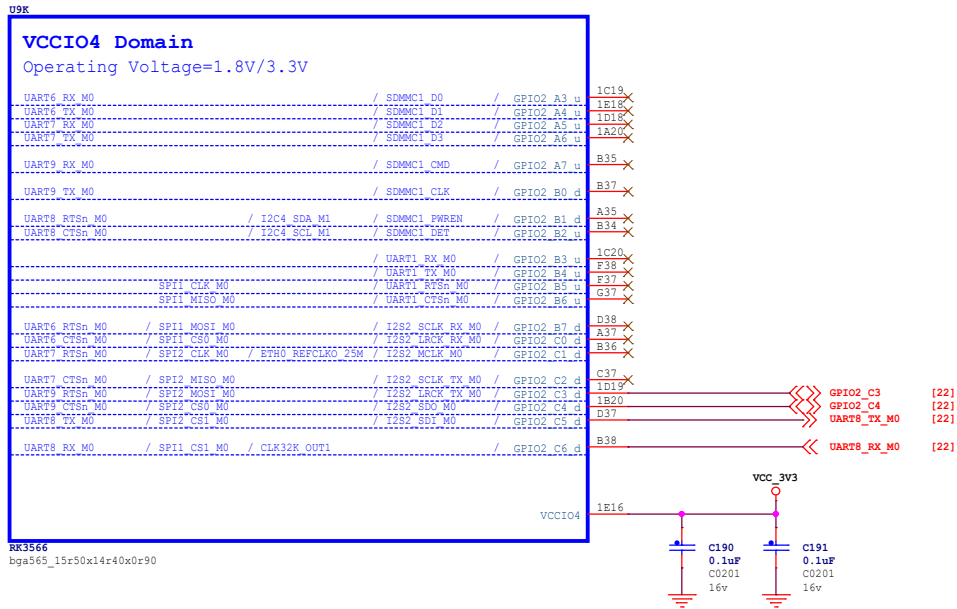

RK3566_O (SARADC/OTP)

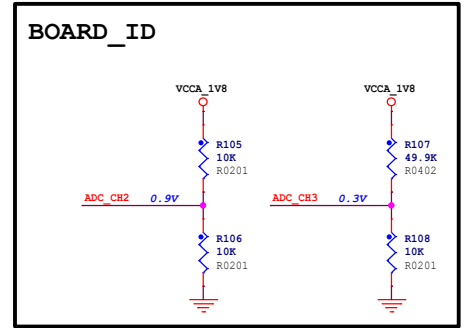
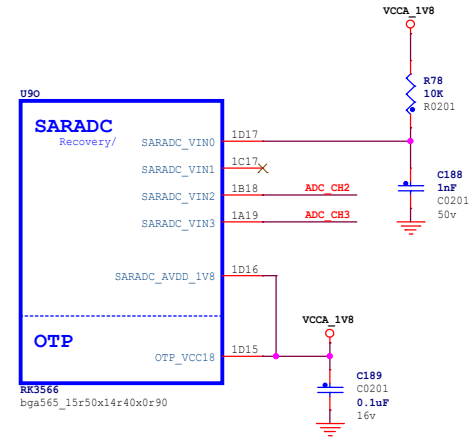

RK3566_N (VCCIO7 Domain)

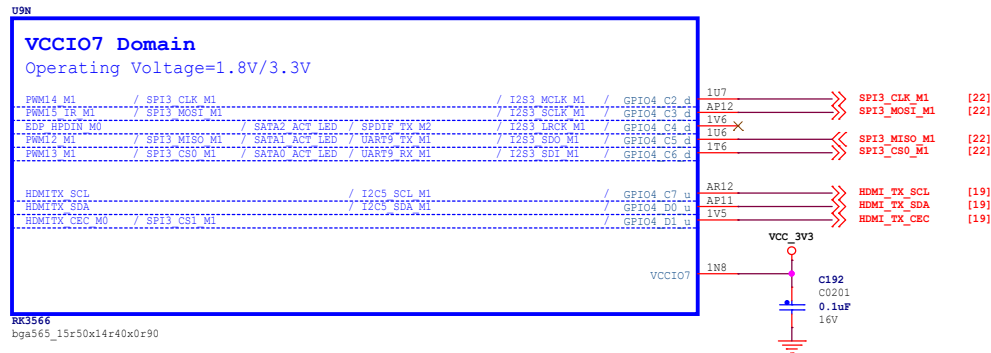

东莞野火电子有限公司 https://yeuosm.tmall.com		
Title	野火_RK3566_LUBANCA7_ZERO_WIFI_原理图	
Size	Document Number	Rev
A3	RK3566_SARADC/GPIO	V0.2
Date:	Friday, December 09, 2022	Sheet 17 of 22

RK3566_L (VCCIO5 Domain)

U9L

VCCIO5 Domain

Operating Voltage=1.8V/3.3V

VOP BT1120 D0	/ SPI1 CS0 M1		/ SDMMC2 D0 M1	/ GPIO3 A1 d
VOP BT1120 D1		/ GMAC1 TXD2 M0	/ I2S3 MCLK M0	/ SDMMC2 D1 M1
VOP BT1120 D2		/ GMAC1 TXD3 M0	/ I2S3 SCLK M0	/ SDMMC2 D2 M1
VOP BT1120 D3		/ GMAC1 RXD2 M0	/ I2S3 LRCK M0	/ SDMMC2 D3 M1
VOP BT1120 D4		/ GMAC1 RXD3 M0	/ I2S3 SDO M0	/ SDMMC2 CMD M1
VOP BT1120 CLK		/ GMAC1 TXCLK M0	/ I2S3 SBI M0	/ SDMMC2 CLK M1
VOP BT1120 D5		/ GMAC1 RXCLK M0		/ SDMMC2 DET M1
VOP BT1120 D6		/ ETH1 REFCLKO 25M M0		/ SDMMC2 PWREN M1
PWM8 M0	/ VOP BT1120 D7	/ GMAC1 RXD0 M0	/ UART4 RX M1	/ GPIO3 B0 d
PWM9 M0	/ VOP BT1120 D8	/ GMAC1 RXD1 M0	/ UART4 TX M1	/ GPIO3 B1 d
VOP BT1120 D9	/ I2C5 SCL M0	/ GMAC1 RXDV CRS M0		/ GPIO3 B2 d
VOP BT1120 D10	/ I2C5 SDA M0	/ GMAC1 RXER M0	/ PDM SDI0 M2	/ GPIO3 B3 d
PWM10 M0	/ VOP BT1120 D11	/ I2C3 SCL M1	/ GMAC1 TXD0 M0	/ GPIO3 B4 d
PWM11 IR M0	/ VOP BT1120 D12	/ I2C3 SDA M1	/ GMAC1 TXD1 M0	/ GPIO3 B5 d
PWM12 M0		/ GMAC1 TXEN M0	/ UART3 TX M1	/ GPIO3 B6 d
PWM13 M0		/ GMAC1 MCLKINOUT M0	/ UART3 RX M1	/ GPIO3 B7 d
VOP BT1120 D13	/ SPI1 MOSI M1		/ PCIE20 PERSTa M1	/ PDM SDI3 M2
VOP BT1120 D14	/ SPI1 MISO M1		/ UART5 TX M1	/ I2S1 SDO2 M2
VOP BT1120 D15	/ SPI1 CLK M1		/ UART5 RX M1	/ I2S1 SDO3 M2
				/ I2S1 SCLK RX M2
PWM14 M0	/ VOP PWM M1	/ GMAC1 MDC M0	/ UART7 TX M1	/ PDM CLK1 M2
PWM15 IR M0	/ SPDIF TX M1	/ GMAC1 MDIO M0	/ UART7 RX M1	/ I2S1 LRCK RX M2
				/ GPIO3 C4 d
				/ GPIO3 C5 d

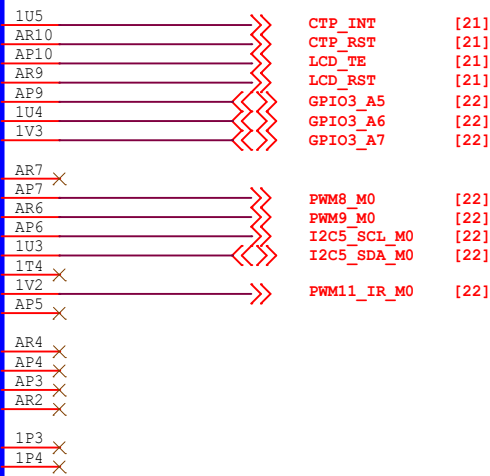

RR3566
bga565_15r50x14r40x0r90

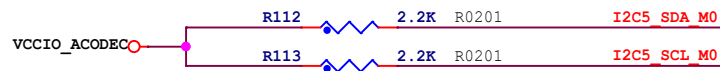

东莞野火电子技术有限公司 https://yehuosm.tmall.com		
Title 野火_RK3566_LUBANCAT_ZERO_WIFI_原理图		
Size A4	Document Number RK3566_VO Interface	Rev V0.2
Date: Thursday, December 08, 2023 Sheet 18 of 22		

HDMI_PORT

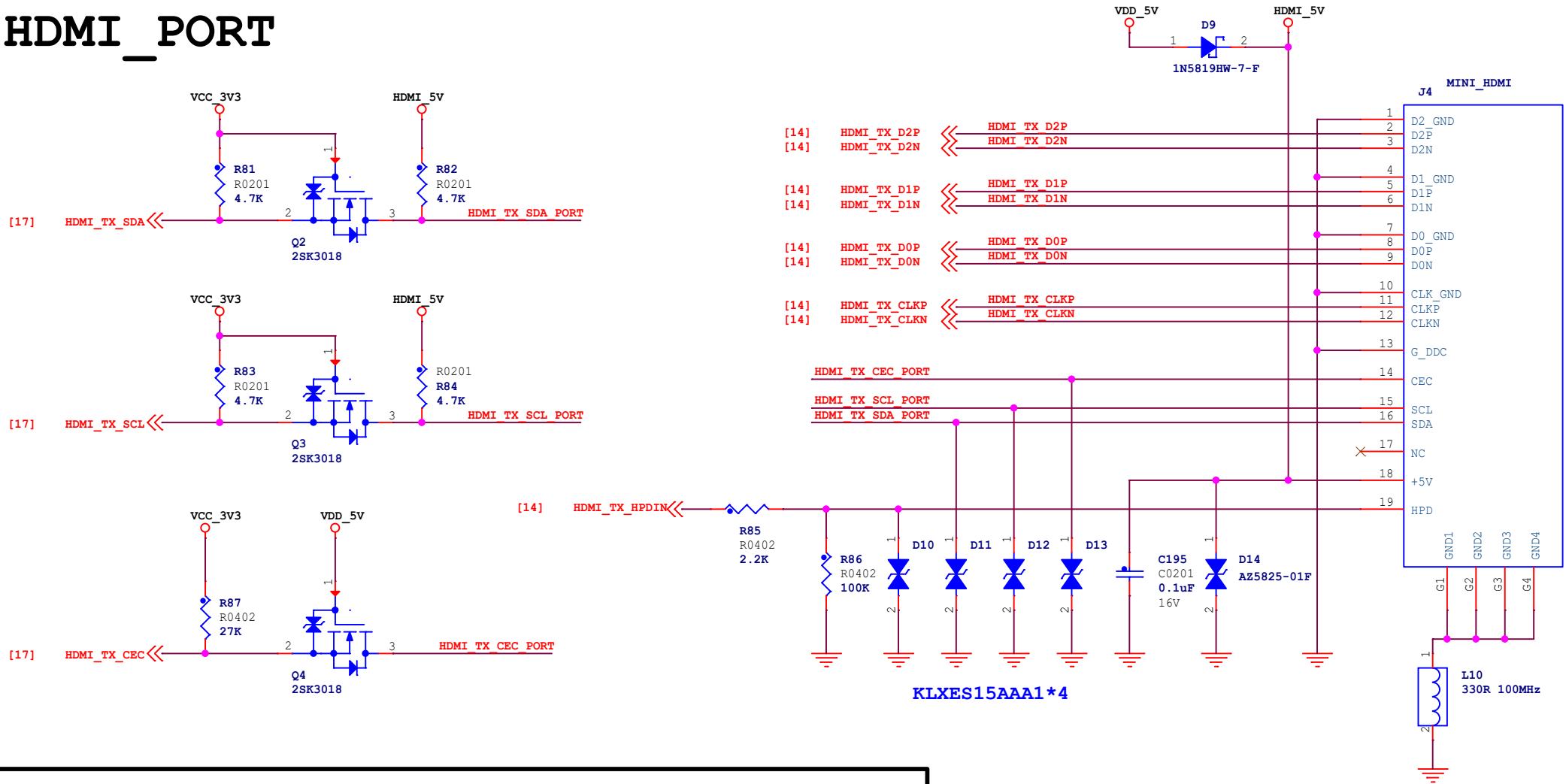

ESD

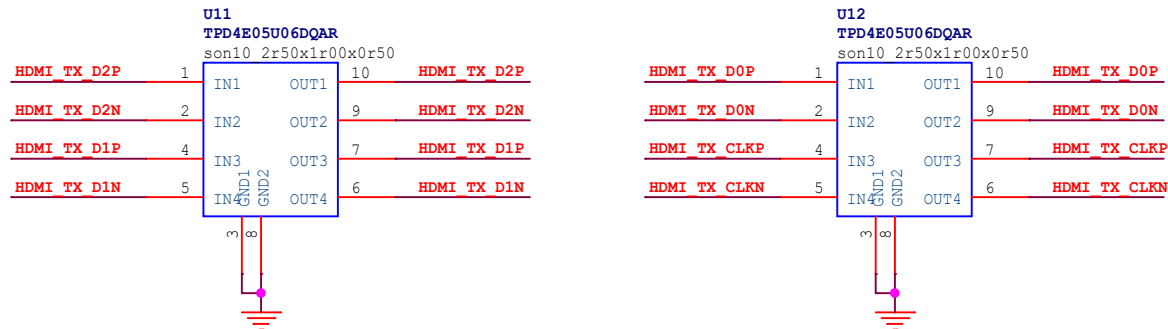

东莞野火电子技术有限公司 https://yehuosm.tmall.com		
Title 野火_RK3566_LUBANCAT_ZERO_WIFI_原理图		
Size A4	Document Number HDMI_PORT	Rev V0.2
Date: Thursday, December 08, 2023 Sheet 19 of 22		

USB_WLAN

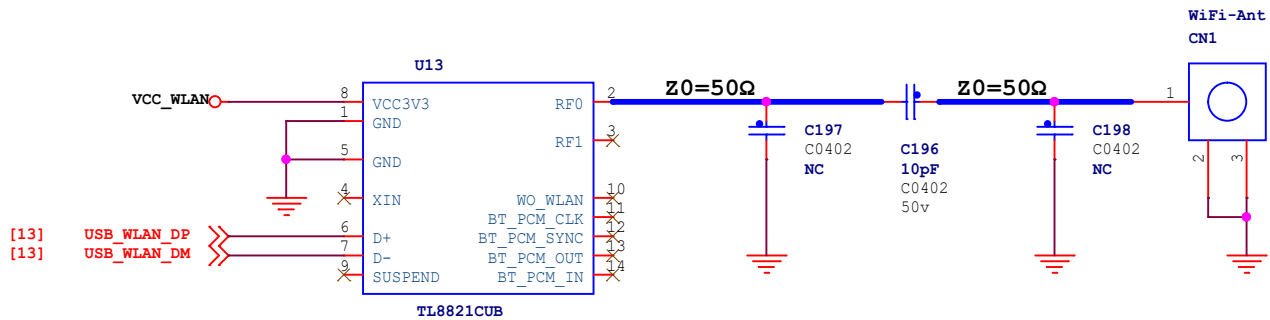

WLAN_Power

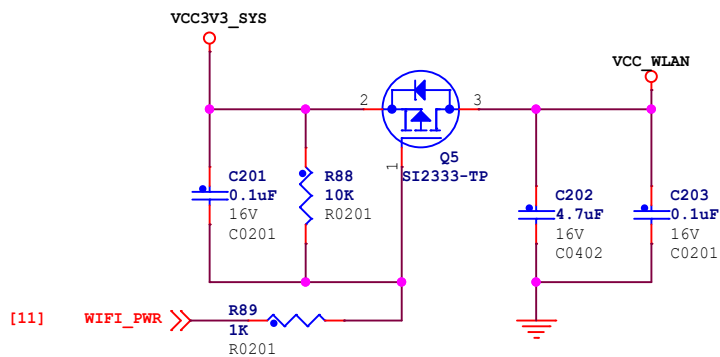

东莞野火电子有限公司 https://yehuosm.tmall.com		
Title 野火_RK3566_LUBANCAT_ZERO_WIFI_原理图		
Size A4	Document Number USB_WLAN	Rev V0.2
Date: Thursday, December 08, 2023 Sheet 20 of 22		

MIPI DSI PORT

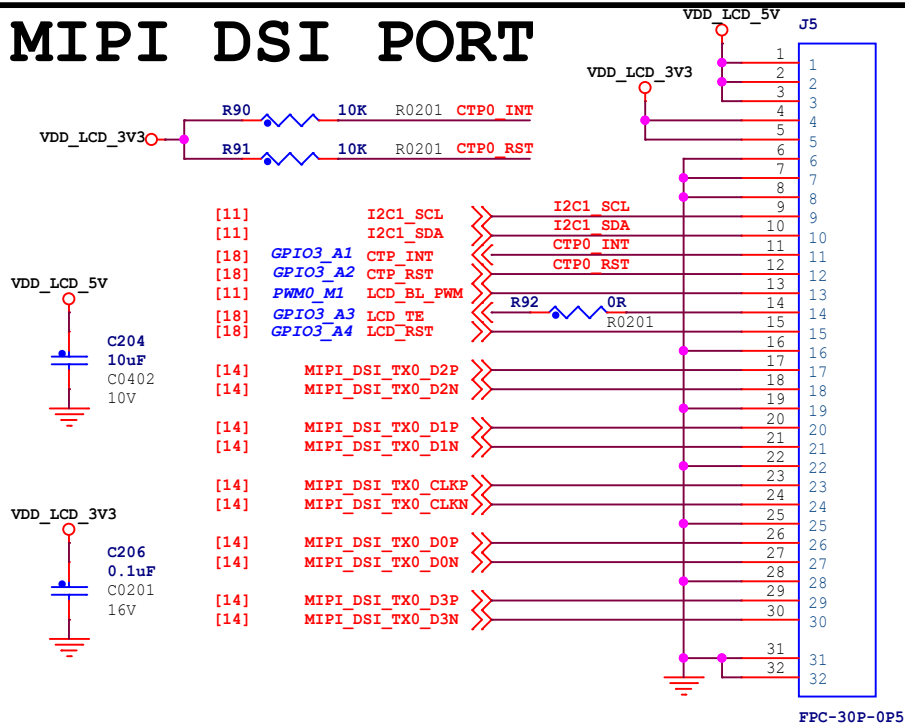

MIPI CSI PORT

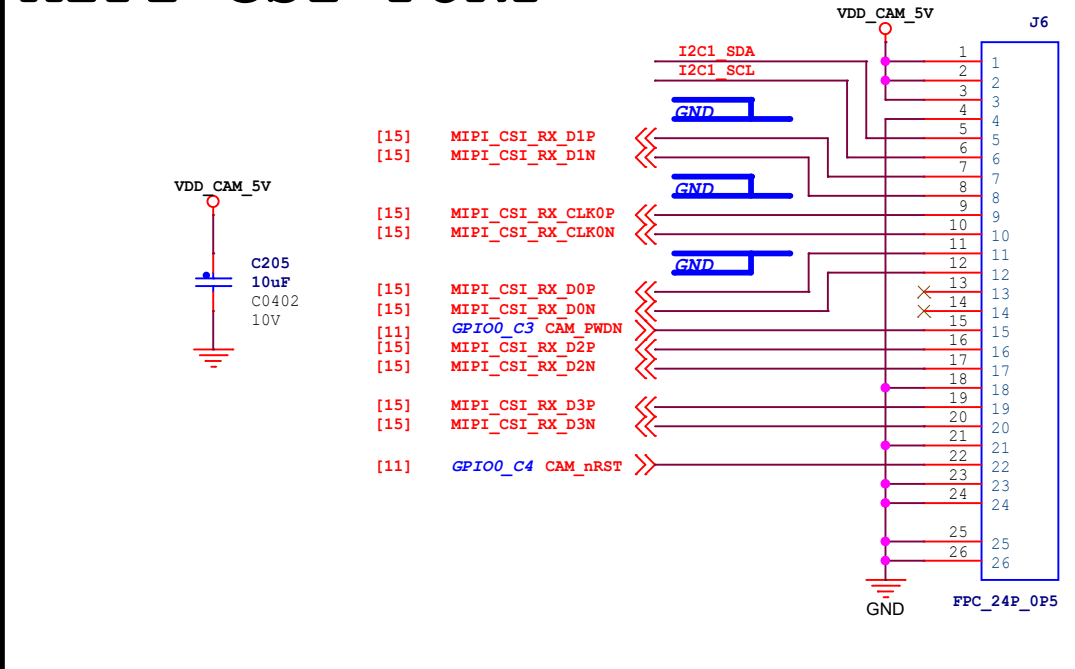

LCD Power

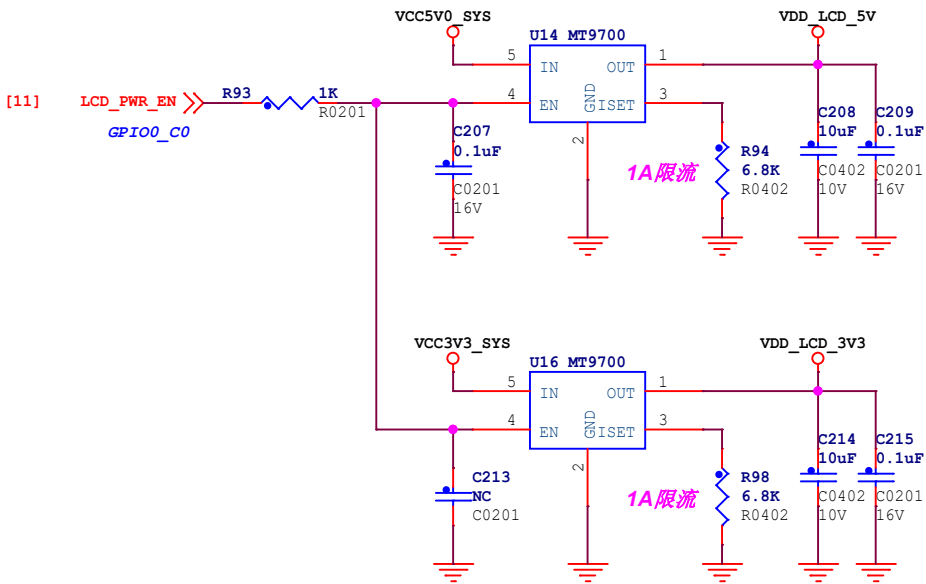

MIPI CSI Power

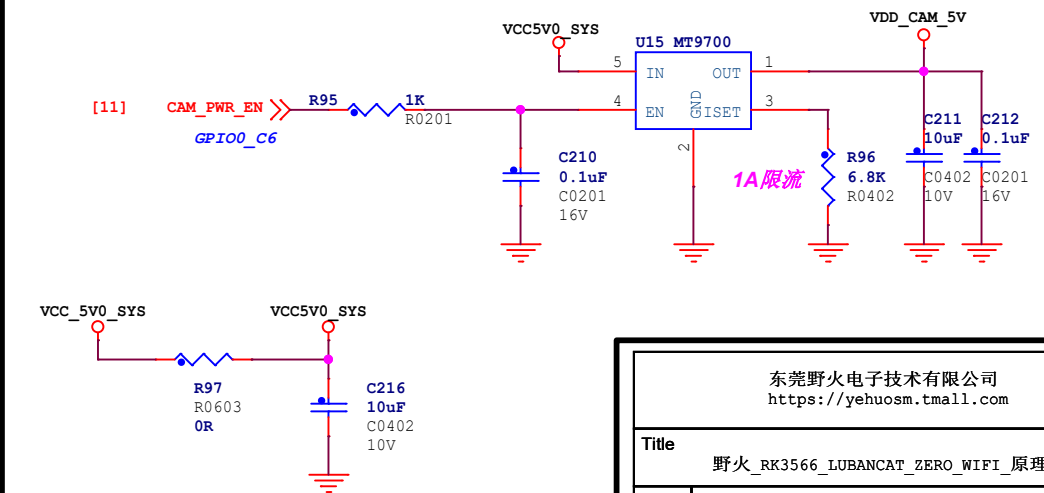

东莞野火电子有限公司
https://yehuosm.tmall.com

Title: 野火_RK3566_LUBANCAT_ZERO_WIFI_原理图

Size: A4	Document Number: MIPI DSI/MIPI CSI_PORT	Rev: V0.2
----------	---	-----------

Date: Friday, December 09, 2022 Sheet 21 of 22

Pin Out

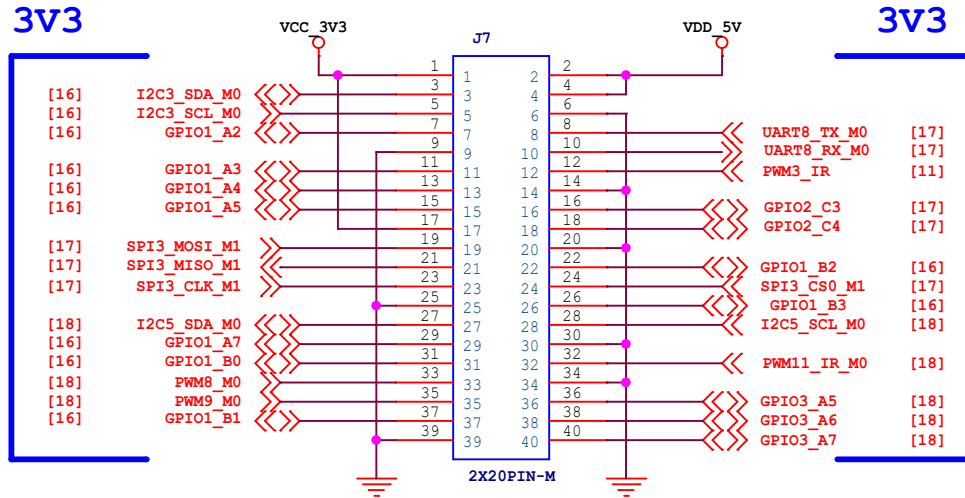

SYS_LED

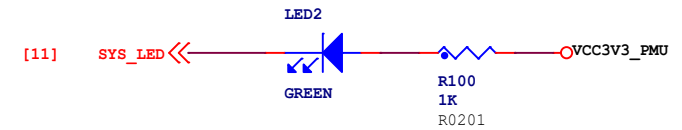

Debug UART2

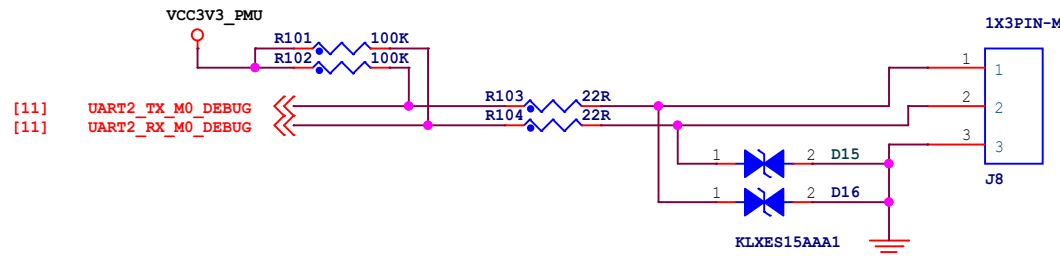

东莞野火电子有限公司
<https://yehuosm.tmall.com>

Title 野火_RK3566_LUBANCAT_ZERO_WIFI_原理图

Size A4	Document Number DEBUG/PIN_OUT	Rev V0.2
---------	----------------------------------	-------------

Date: Friday, December 09, 2022 Sheet 22 of 22